



neptronic®

Multi-Steam Steam Dispersion System



Installation Instructions & User Manual

READ AND SAVE THESE INSTRUCTIONS

Foreword

Neptronic Company Overview

Founded in 1976, we're a private corporation that designs, manufactures and distributes products for the HVAC industry. Our product line includes intelligent controllers, electronic actuators, actuated valves, humidifiers and electric heaters.

Our products are designed and manufactured by over 250 dedicated employees in our 7,500 m² (80,000 ft²) state-of-the-art facility located in Montreal, Canada. Using a vertical integration model, our entire manufacturing chain is under one roof, from software and hardware development, to SMT circuit board assembly, to sheet metal fabrication, to product testing, ensuring that our products are engineered to last.

We currently hold several national and international patents and with our continued commitment to research and development, we provide innovative products and technologies for the ever-evolving challenges of the HVAC industry. Exporting over 70% of our sales, we have an exclusive distribution network around the globe that provides comprehensive solutions to our worldwide customers.

About the Manual

These installation and operation instructions have been developed to facilitate the installation of the Multi-Steam.

- The strict application of these instructions will ensure the conformity of your installation and operation as per the manufacturer's recommendations.
- The application of these instructions is one of the conditions for the application of the warranty.
- The application of these instructions does not ensure, at any time conformity to procedures, regulation or local codes.

2026[®]: All rights reserved. This document cannot be reproduced totally or partially by any means whether, electronic, mechanical, photocopy, recording or other, without prior written authorization of Neptronic.

Correct Use

Neptronic systems and its products are designed only for humidification use. Any other application is not considered appropriate for the intended purpose. The manufacturer cannot be made liable for any damage resulting from incorrect use.

General Warranty

This product is subject to the terms and conditions described at <http://www.neptronic.com/Sales-Conditions.aspx>.

Table of contents

1. Presentation	2
2. Characteristics.....	2
2.1. Accessories	2
2.2. Dimensions.....	2
3. Assembly instructions for Multi-Steam collapsible	3
3.1. Description of components supplied.....	3
3.2. Assembly instruction.....	3
4. Mechanical installation	6
4.1. General recommendations	6
4.2. Pitch (Horizontal air flow).....	6
4.3. Typical installation of Multi-Steam (Horizontal air flow)	6
4.4. Pitch (Vertical air flow).....	7
4.5. Typical installation of Multi-Steam (Vertical air flow).....	7
5. Steam supply line connection	8
5.1. Typical installation	8
5.2. General recommendations	9
5.3. Single steam outlet.....	10
5.4. Multiple steam outlets.....	10
5.5. Multiple steam outlets (Multiple humidifiers).....	10
5.6. Condensate Drain outlet.....	10
6. Start up procedure	11
7. Maintenance	11
8. Troubleshooting guide	11

1. Presentation

Thank you for choosing a Neptronic® product. The Multi-Steam is a multiple stainless steel dispersion tubes connected to a stainless steel header. The Multi-Steam manifold is custom built for the duct or the air handling unit (AHU). The dispersion tubes include brass insertion nozzles (eyelets) to prevent condensate from escaping. The Multi-Steam can be completely welded at the factory or collapsible for field assembly. Multi-Steam manifolds are used for very short absorption distances.

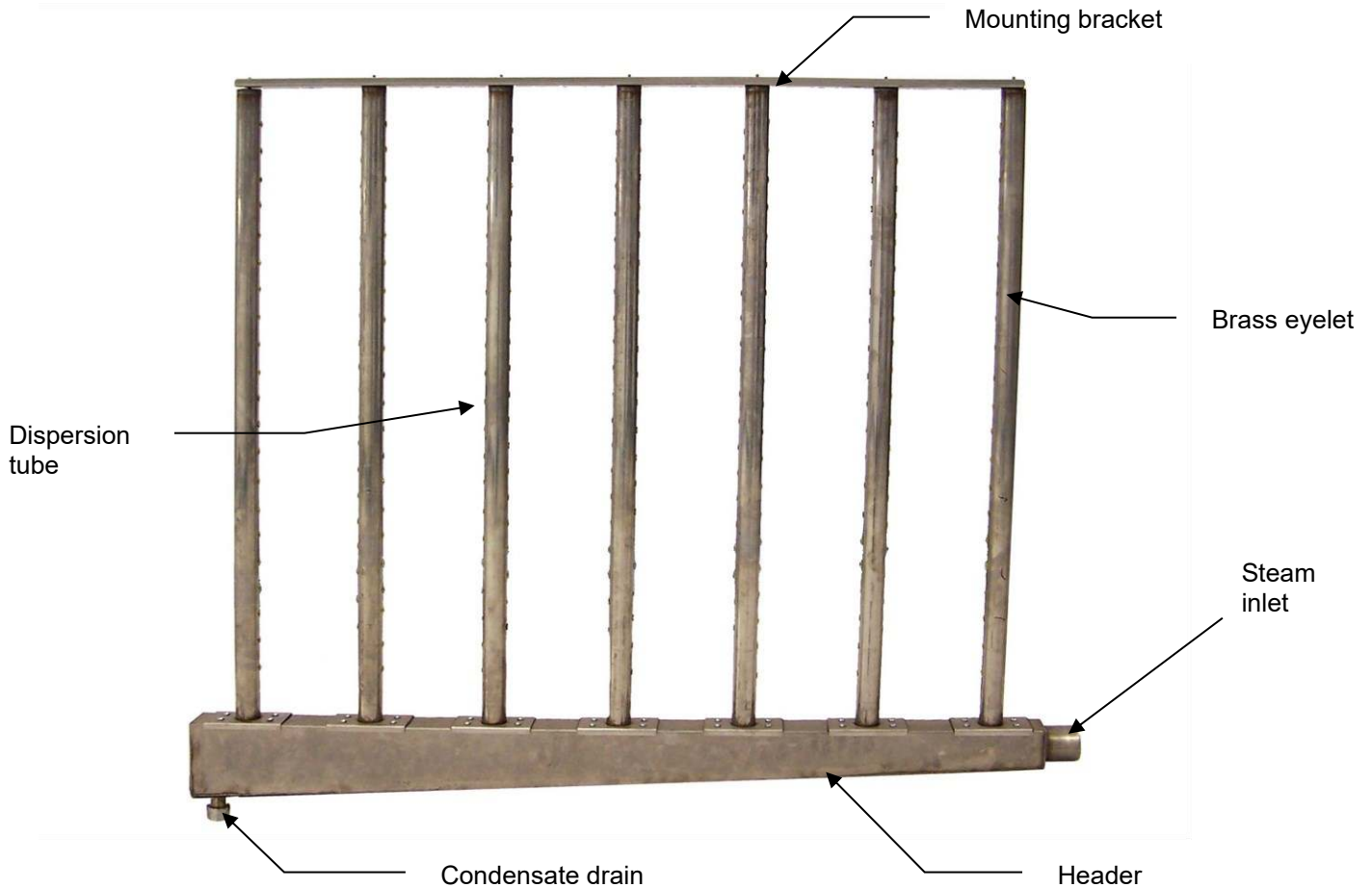

(Fig. 1)

2. Characteristics

2.1. Accessories

Typical accessories include the hose, clamps and MS connection.

2.2. Dimensions

The Multi-Steam manifold is custom built for the duct or the air handling unit (AHU), so dimension depends on dimension of the duct or of the AHU.

3. Assembly instructions for Multi-Steam collapsible

3.1 Multisteam SD assembly

3.1.1 Description of components supplied

- 1) Header (qty: 1)
- 2) Dispersion tubes (qty: as per order)
- 3) Gaskets (qty: 1 per vertical tube)
- 4) Mounting bracket (qty: 1)
- 5) Brass nuts (qty: 1 per vertical tube)
- 6) Brass screws (qty: 4 per vertical tube)

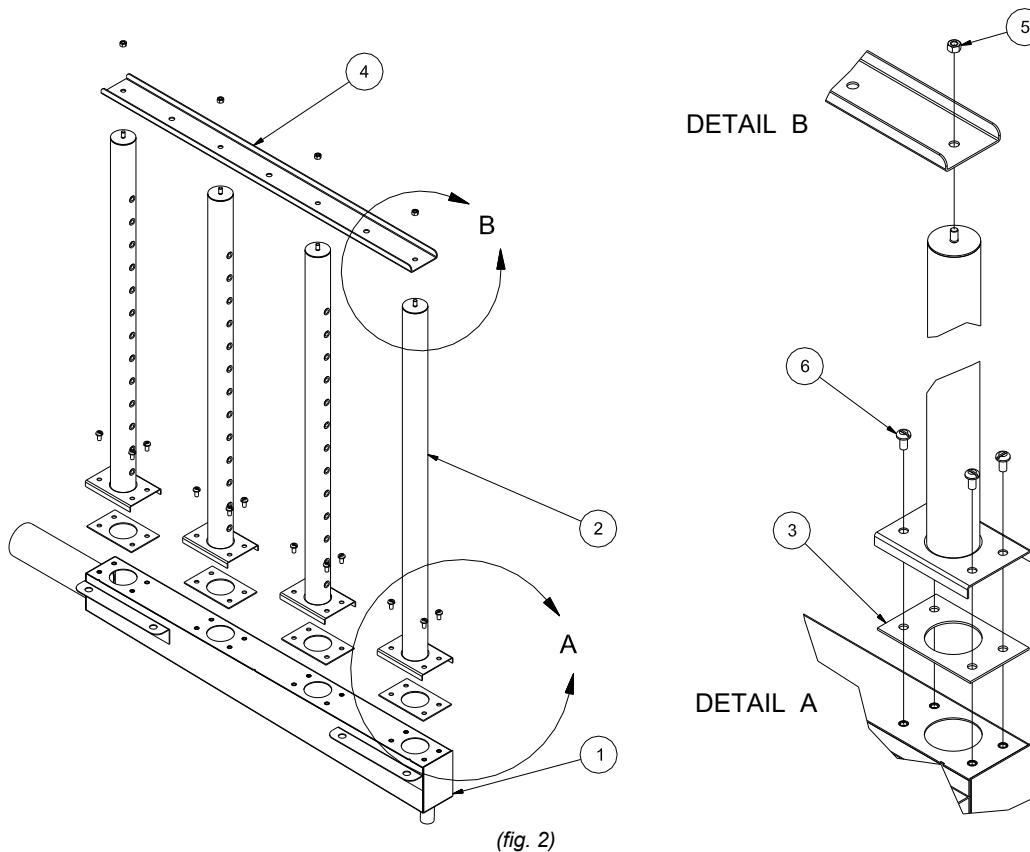

3.1.2 Assembly instruction

1. Identifying the distribution tubes

- Two of the dispersion tubes have only one row of brass eyelets. These two dispersion tubes are to be installed at the extremities of the header steam outlets with the brass eyelets facing toward the inside.
- The remaining dispersion tubes are identical, they have two rows of brass eyelets and to be installed on the others steam outlets of the header.

2. Installation of the distribution tubes

- Place a gasket over the steam outlet of the header. Align the holes on the gasket with the holes on the header (detail A).
- Align the mounting plate holes of the distribution tube with the holes on the gasket.
- Use four screws to secure the distribution tube to the header.
- Repeat step 2 for the remaining distribution tubes.

3. Installation of the mounting bracket

- Place the mounting bracket on top of the distribution tubes, the bents on the bracket should be facing toward the top (detail B).
- Align the holes on the mounting bracket with each stud screws on the distribution tubes.
- Use the nuts to secure the mounting bracket to all the distribution tubes.



3.2 Multisteam HD assembly

3.2.1 Description of components supplied

- 1) Header (qty: 1)
- 2) Dispersion tubes (qty: as per order)
- 3) Cover
- 4) Mounting bracket (qty: 1)
- 5) Insulation
- 6) Brass screws (qty: 4 per vertical tube)

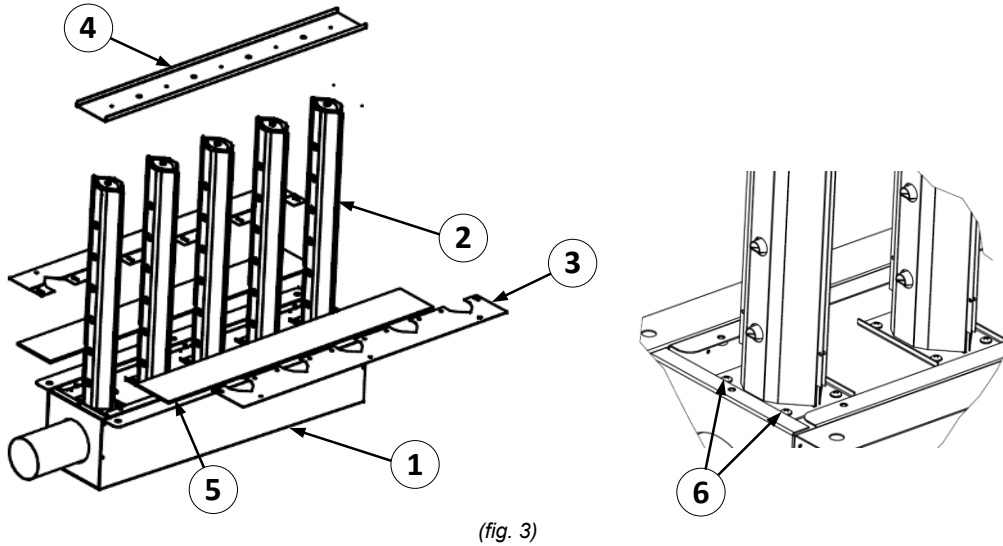

3.2.2 Assembly instruction

1. Installation of the distribution tubes

- Remove the top cover and insulation.

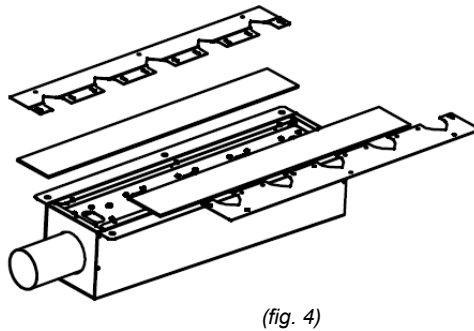

- Align the tubes with the mounting holes on the header.

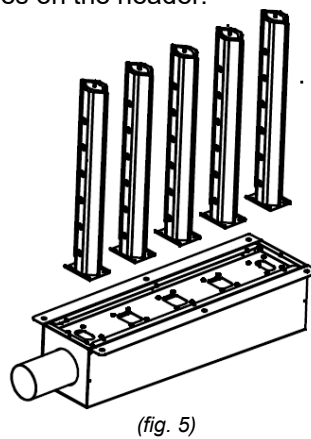



- Position the tubes to ensure that the nozzles are not facing each other (see diagram) prior to securing them. Secure the tubes with the provided screws.

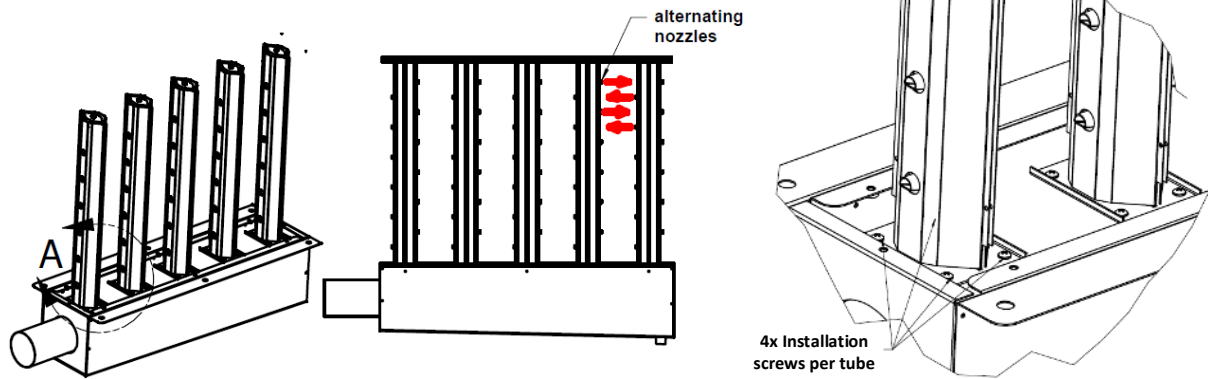

(fig. 6)

2. Installation of the top and mounting bracket

- Replace the insulation, both covers and the top bracket.

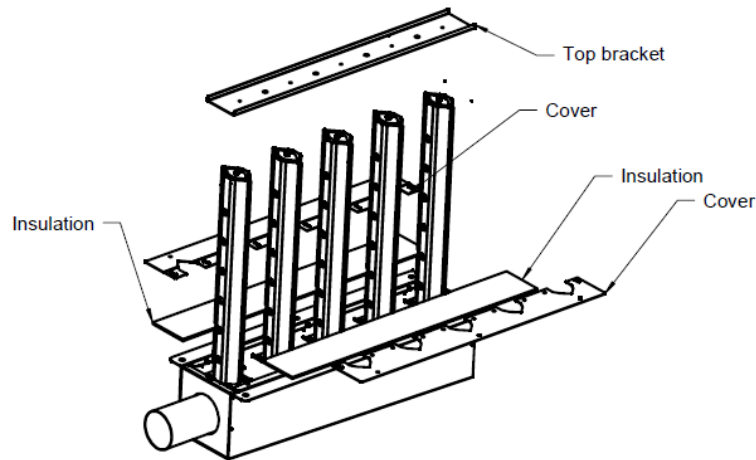

(fig. 7)

- Secure the covers with the screws and top bracket by using the provided nuts.

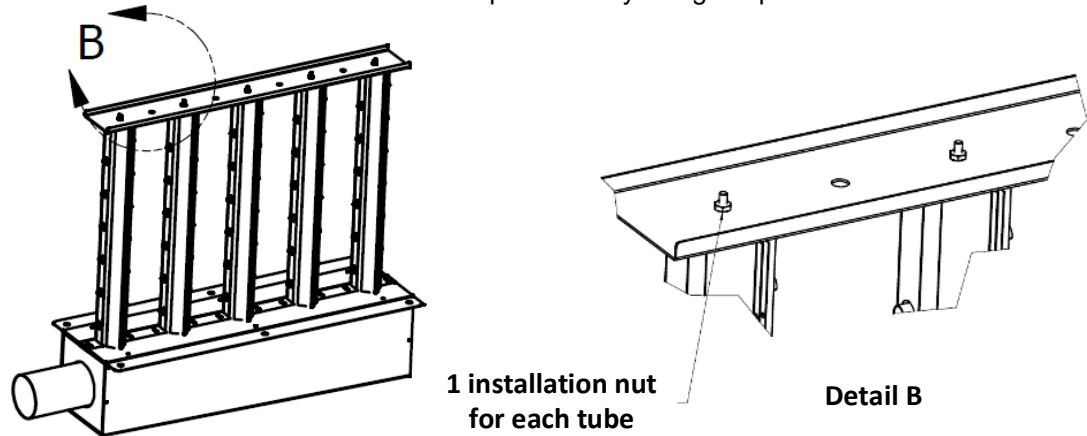

(fig. 8)

4 Mechanical installation

4.2 General recommendations

- **IMPORTANT:** Mechanical installation should conform to Local and National Codes.
- Location: Plan a location which is easy to access to permit a proper installation and inspection of Multi-Steam.
The Multi-Steam is centered side to side in the duct or across the face of a coil in an air handler.
- To protect against water damage, it is recommended that a sealed section of duct or a drip pan with drain should be installed beneath the Multi-Steam.

4.3 Pitch (Horizontal air flow)

- Installing the Multi-Steam inside a horizontal air flow duct or in an AHU, you must ensure that the mounting bracket is level horizontally.
- The Multi-Steam's header is already pitched toward the condensate drain from the factory when the multiple dispersion tubes are level vertically.
- The eyelets must be perpendicular to the airflow.

4.4 Typical installation of Multi-Steam (Horizontal air flow)

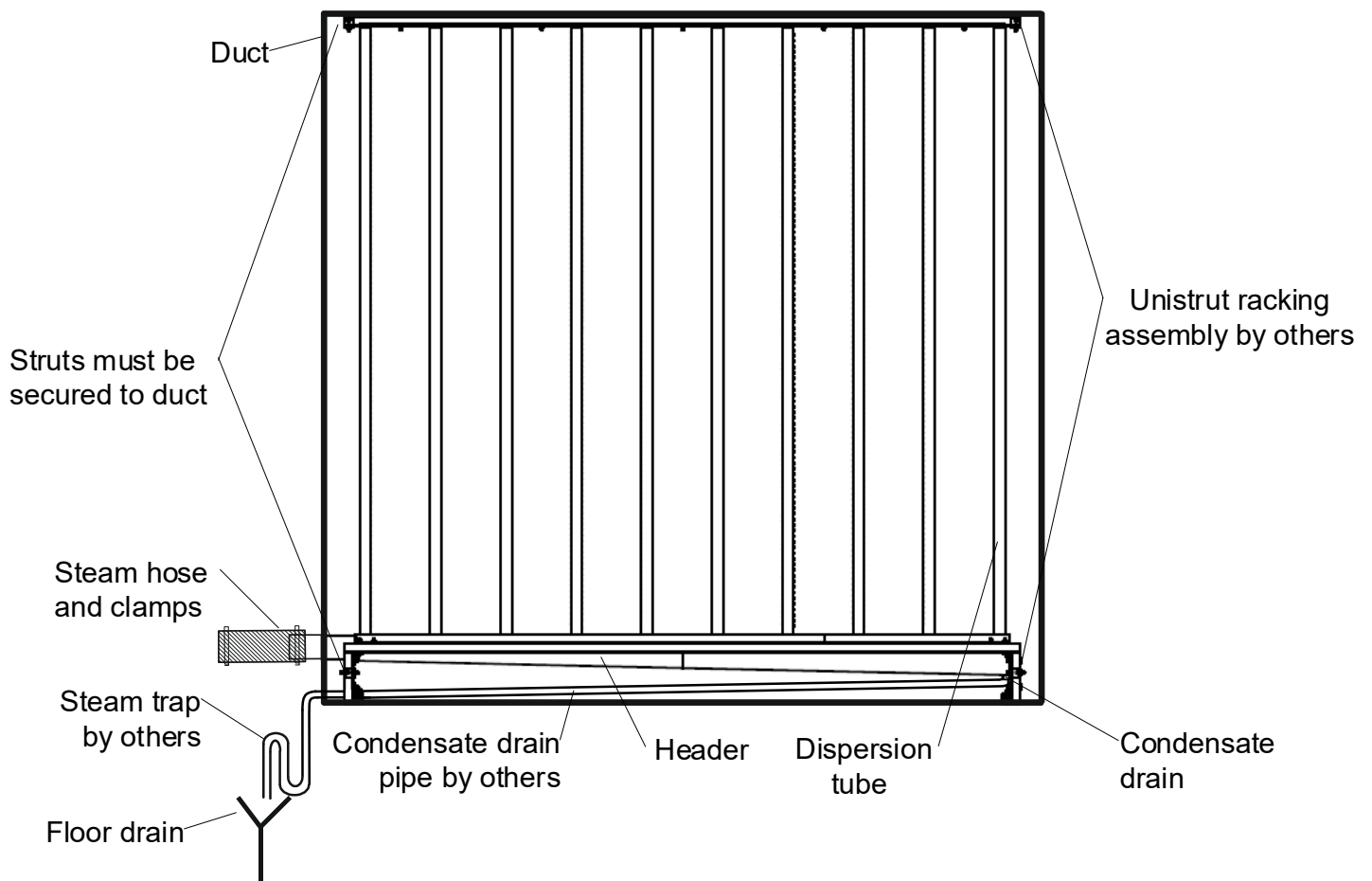

(Fig. 9)



4.5 Pitch (Vertical air flow)

- Installing the Multi-Steam inside a vertical air flow duct, you must ensure that the header is pitch properly.
- The Multi-Steam header must be pitch toward the condensate drain.
- A minimum of 10 degree pitch must be kept on the dispersion tubes to allow the condensate to flow toward the header.
- The eyelets must be perpendicular to airflow.

4.6 Typical installation of Multi-Steam (Vertical air flow)

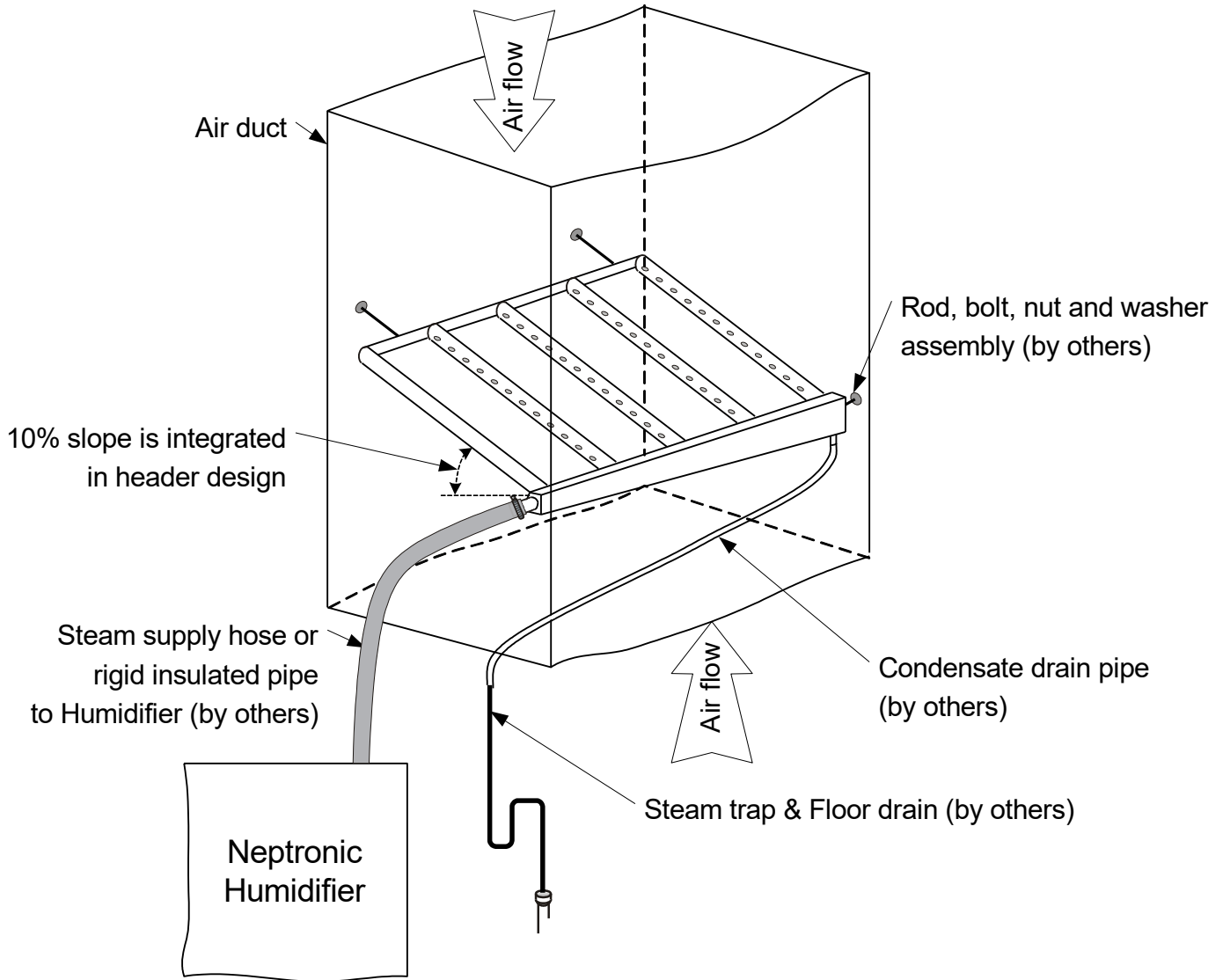

(Fig. 10)

5 Steam supply line connection

5.2 Typical installation

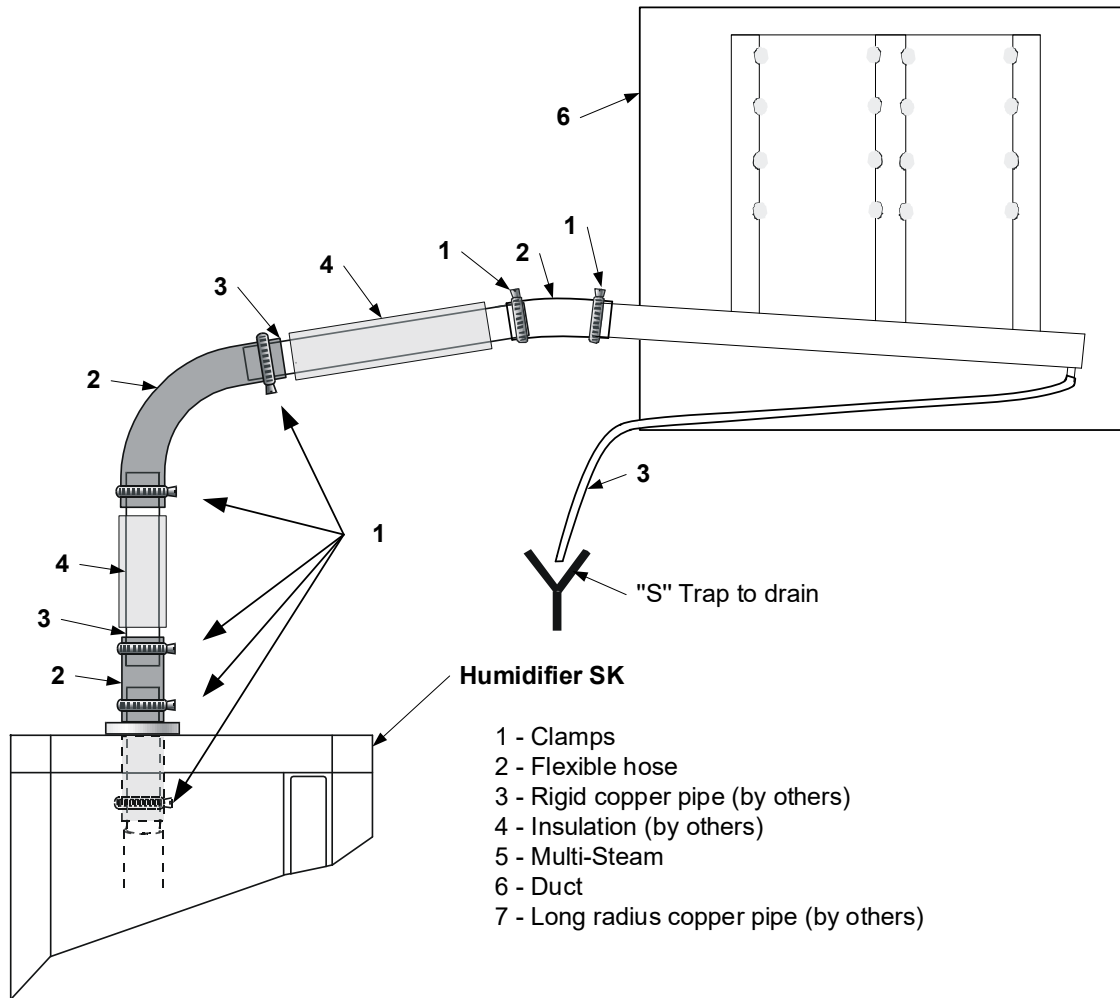

Min. downward pipe slope () = 2% (1/4"/12" - 20mm/1m)

Min. upward pipe slope () = 15% (2"/12" - 150mm/1m)

(Fig. 11)



5.3 General recommendations

Follow these general installation rules to avoid any condensation accumulation which can cause severe water accumulation in the duct or a humidifier malfunction.

IMPORTANT:



- **Risk of malfunction. Avoid kinks, sags and areas where condensate can become trapped.**
- Plumbing installation should conform to Local and National Codes

- Ensure that the minimum steam pipe gradient must be 2% downward and 15% upward, i.e., 1/4"/12" (20 mm per 1 m) run and 2"/12" (150 mm per 1 m) run to ensure continuous drainage of condensation back to the humidifier or to a steam trap.
- Use flexible steam hoses for short runs (up to 16 feet or 5 m) or for interconnecting between the rigid pipe runs.** Ensure that there are no kinks and that the hose does not sag when using flexible tubing. Do not use flexible hoses for curved portions of the steam line.
- Determine the total steam line for insulated hard piping based on the capacity of the humidifier, such as one equivalent foot for each lb/hr capacity of the humidifier (0.67 m for each kg/hr) with a maximum of 50 feet (15 m).** Consult factory for longer steam line runs.
- If you are using a rigid copper pipe, use insulation to diminish condensate build-up.**

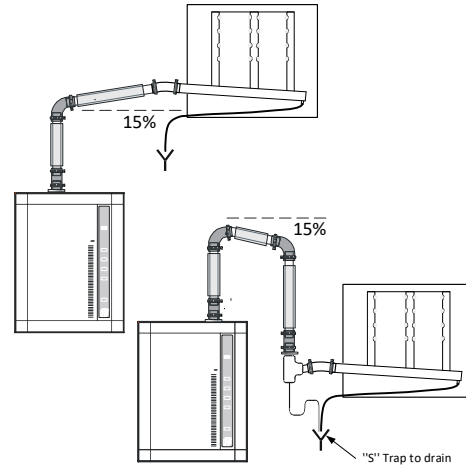
Min. downward pipe slope () = 2% (1/4"/12" - 20mm/1m)
 Min. upward pipe slope () = 15% (2"/12" - 150mm/1m)



Correct installations

Min. downward pipe slope () = 2% (1/4"/12" - 20mm/1m)
 Min. upward pipe slope () = 15% (2"/12" - 150mm/1m)

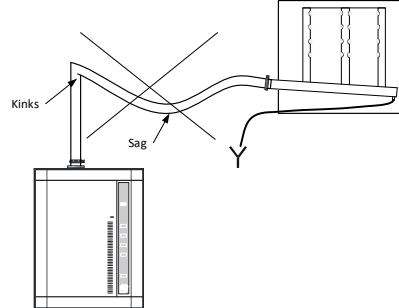

Incorrect installation
 (Fig. 12)



5.4 Single steam outlet

- Run one steam line from the steam outlet of the evaporation chamber of the humidifier to the Multi-Steam header (a reducer is welded at the inlet of the Multi-Steam header).
- Use steam hose and clamps to make the connection from hard insulated copper pipe to the Multi-Steam and the humidifier.

5.5 Multiple steam outlets

- If the humidifier supplying the steam has more than one steam outlet from the evaporation chamber a MS connector must be ordered with the Multi-Steam.
- Install the same number of steam lines as the steam outlets from the evaporation chamber to the MS connector.
- Position the MS connector close to the humidifier or to the Multi-Steam while maintaining the proper pitch.
- **IMPORTANT:** Never reduce the diameter of the steam lines. Improper size will over-pressurize the humidifier.

5.6 Multiple steam outlets (Multiple humidifiers)

- If multiple humidifiers are supplying the steam to the Multi-Steam, multiple MS connectors must be ordered with the Multi-Steam.
- Install the same number of steam lines as the steam outlets from the evaporation chamber to the MS connector.
- Position the MS connectors close to the humidifier or to the Multi-Steam while maintaining the proper pitch.
- **IMPORTANT:** Never reduce the diameter of the steam lines. Improper size will over-pressurize the humidifier.

5.7 Condensate Drain outlet

- The Multi-Steam has a 1/2" (15mm) NPT (or BSPT) condensate drain connection.
- Run a pipe (same size as the condensate drain connection) as directly as possible from the condensate drain outlet to the floor drain with a proper slope and install a steam trap to prevent any steam leakage from the drain.
- The steam trap (S Type) should be installed higher than the static pressure of the system by at least 2 inches (51mm).

6 Start up procedure

Follow this start-up procedure to avoid improper system operation:

- Ensure that plumbing connections have been done in accordance with the instructions in this manual.
 - a) Verify that the steam supply line is connected properly to the Multi-Steam.
 - b) Verify that the Multi-Steam is properly pitched.
 - c) Verify that the Multi-Steam condensate drain is connected to the drain line.

7 Maintenance

- Inspect the Multi-Steam at start up and during normal operation.

8 Troubleshooting guide

Problem	Causes	Corrective actions
<p style="text-align: center;">Multi-Steam discharges water inside the duct or AHU.</p>	<ul style="list-style-type: none"> • Steam supply line is not insulated. • Steam supply line is not properly drained or sloped. • The Multi-Steam condensate drain is blocked or drain line is not properly sloped. • The Multi-Steam is not properly pitched. • Steam or condensate is leaking from the gasket on the Multi-Steam collapsible. 	<ul style="list-style-type: none"> • Insulated the steam supply line. • Install steam trap to remove the condensate from the steam supply line. • Slope the steam supply line properly as per instruction. • Verify the condensate drain line. • Pitch the Multi-Steam as per instructions. • Replace the gasket (p/n SP 6867).

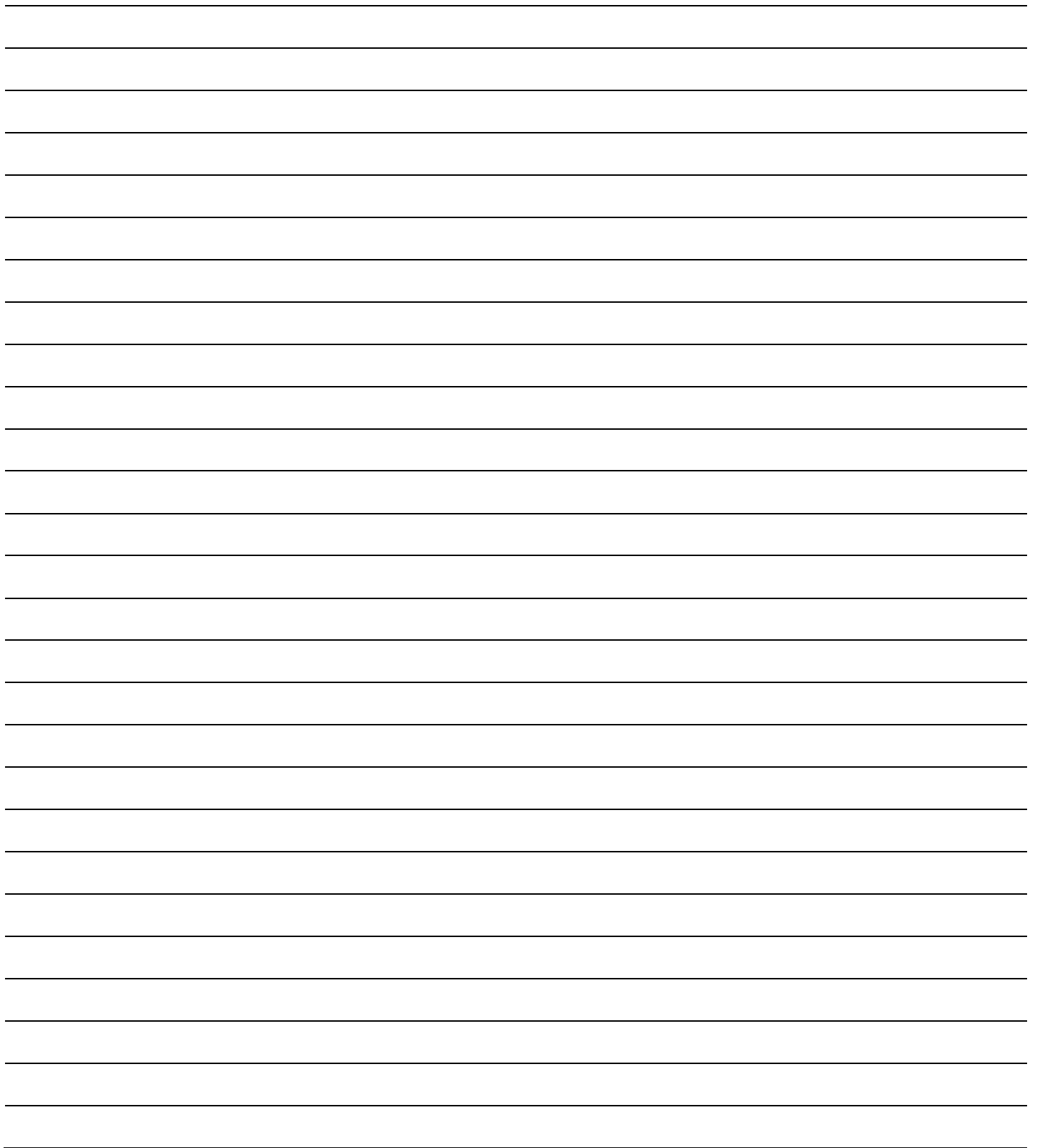



neptronic®

400 Lebeau blvd, Montreal, Qc, H4N 1R6, Canada

www.neptronic.com

Toll free in North America: 1-800-361-2308

Tel.: (514) 333-1433

Fax: (514) 333-3163

Customer service fax: (514) 333-1091

Monday to Friday: 8:00am to 5:00pm (Eastern time)