

SKD DIRECT STEAM INJECTION HUMIDIFIER

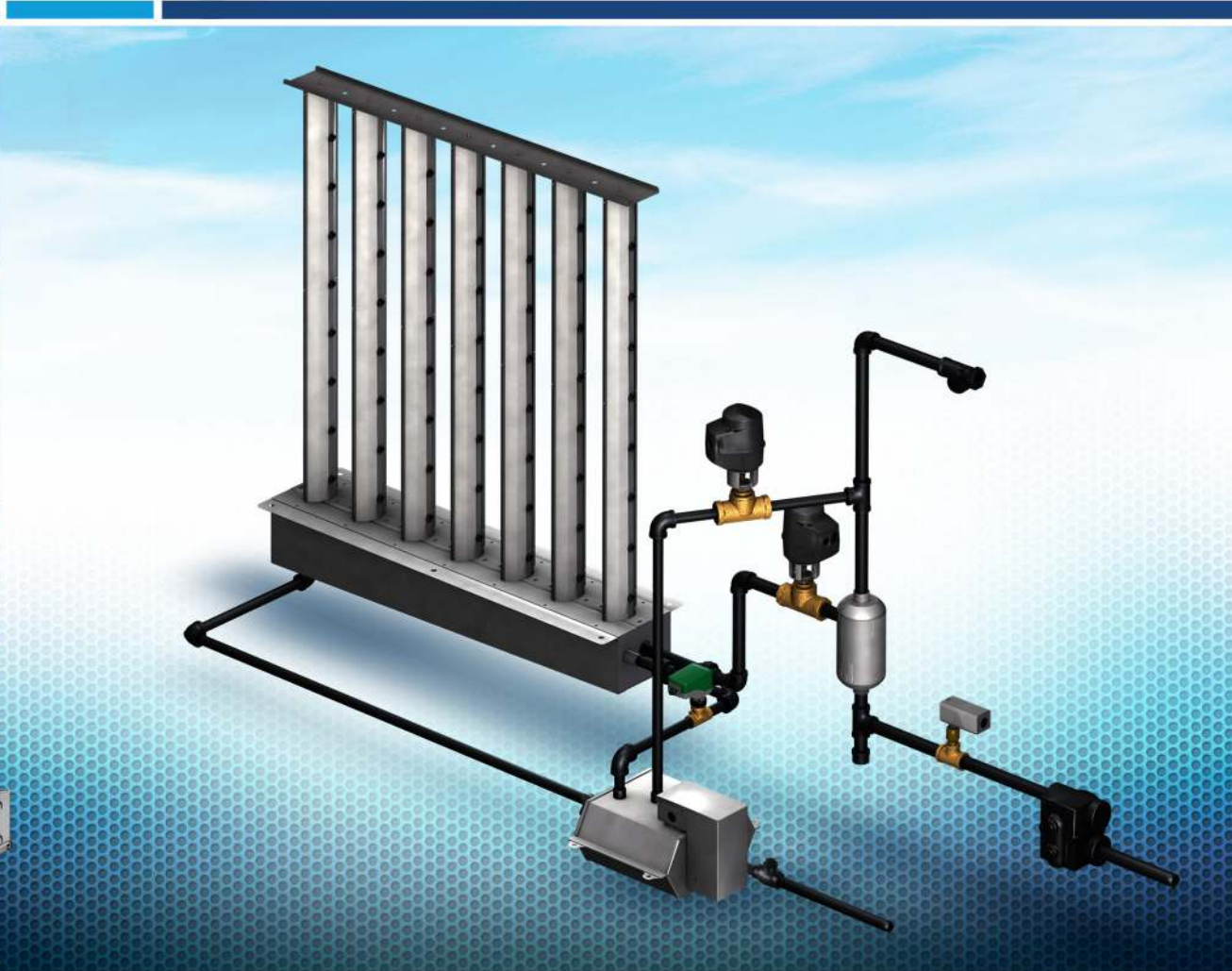

neptronic®
www.neptronic.com

The SKD direct steam injection system uses low pressure steam from an in-house boiler to humidify the air.

SKD Advantages

- Custom designed to meet your specific steam capacity and non-wetting distance requirements
- 5 steam distribution configurations available: Multi-Steam™, Multi-Steam™ HD, or Jacketed (Single Tube, Multi-Tube, or Mini Rack)
- Unique Electronic Steam Controller (ESC) manages the sequence of operation to optimize energy efficiency and prevent condensate ejection
- NEW: Optional patent-pending pressurized condensate return (PCR) system. No gravity drain – no maintenance – returns condensate to steam source

Typical Applications

The SKD steam injection system is the ultimate solution for applications where clean low pressure steam is available, such as:

■ Hospital/
Health Care

■ Museums

■ Laboratories

■ Universities

■ Airports



Typical Installation

Every SKD Steam Injection Humidifier comes with all required accessories for a complete installation. Depending on the selected configuration, we will supply:

- Isolating valve
- Steam control valve
- Temperature sensors
- Steam separator
- Strainer
- Steam traps
- ESC controller

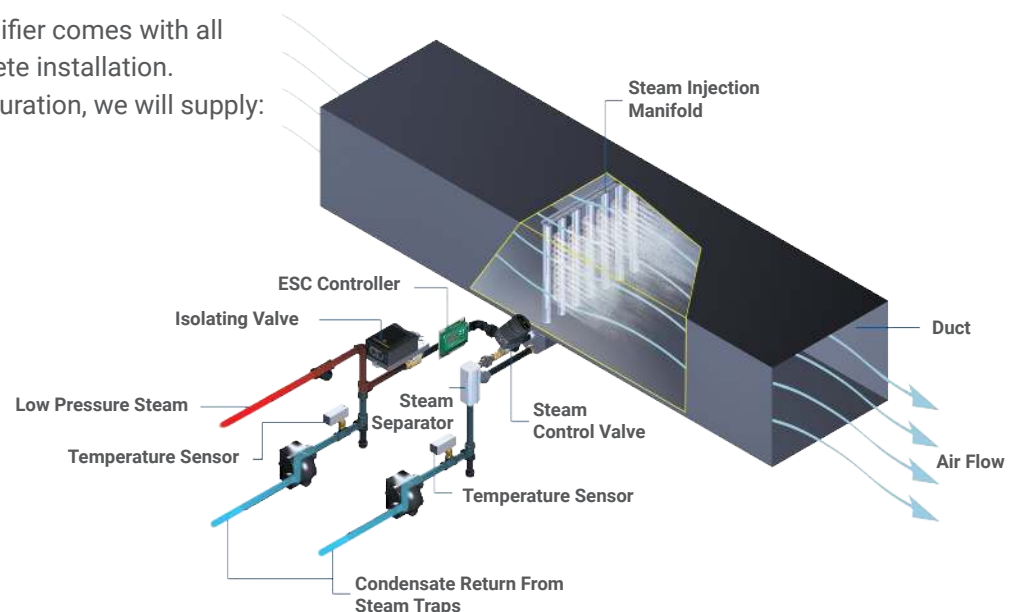

System Overview

Steam Separator

Supplies condensate-free steam to the steam control valve, while discharging condensate to the steam trap

Temperature Sensor

Monitors steam temperature and detects abnormal condensate level to ensure safe operation

F&T Steam Trap

Eliminates condensate from the steam line

Steam Control Valve



Provides full modulation of the low pressure steam flow for a better control of the humidity level

Steam Distribution System

Multi-Steam Configuration

- Multi-Steam™ SD
 - Multi-Steam™ HD
- Jacketed Tube Configuration
- Single Tube
 - Multi-Tube
 - MiniRack

Isolating Valve



Controls steam supply to the jacket in a Multi-Tube configuration, (mandatory as per ASHRAE standard 90.1 for all jacketed tube configurations)

PCR

Optional patent-pending pressurized condensate return (PCR) system. No gravity drain - no maintenance - returns condensate to steam source

ESC Controller

Unique in the Industry

- Microprocessor-based field configurable controller
- Centralized wiring of sensors, valves and humidity controls
- Easy start-up and diagnostics
- 4 buttons and large LCD for simple configuration
- Factory pre-configured operating temperature range
- Automated linear capability by adjusting the control valve stroke to supply the appropriate steam capacity
- 24 Vac operation
- BACnet or Modbus compatible

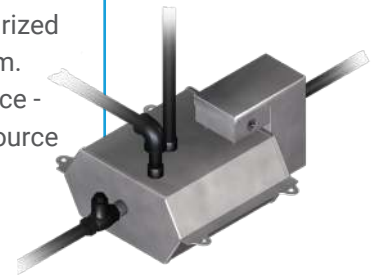

Multi-Stream Distribution

This configuration consists of multiple vertical dispersion tubes mounted on a single horizontal header. Upon a demand for humidity, the ESC controller slowly opens the steam modulating valve feeding steam to the dispersion tubes through a single horizontal header. The steam escapes the dispersion system through multiple nozzles on the vertical tubes and mixes with the airflow to maintain the desired humidity level.

Common Features

- Medium to high capacity applications: 2 to 750 kg/h; higher capacities also available
- Short non-wetting distance
- Pre-configured ESC controller manages sequence of operation
- 100% stainless steel construction (maintenance free)
- Optional pressurized condensate return (PCR) system

Multi-Steam™ SD

- Lowest capital cost steam injection system
- Easiest installation...contractor's favorite
- Lowest heat transferred to the airstream
- Header with built-in slope for improved condensate elimination

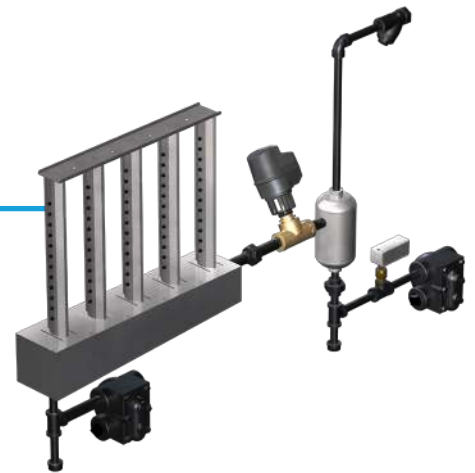

Multi-Steam™ HD

- Same as Multi-Steam™ SD plus: X-Stream™ Technology

X-Stream™ Technology

- Included in Multi-Steam™ distributors
- High efficiency insulated steam distributor (channel and header) with steam ejector eyelets
- Double wall 304 stainless steel with encapsulated Armacell UT/Solaflex™ foam insulation
- Specially engineered 304 stainless steel eyelets prevent condensate ejection on start up and any modulating humidity demand
- Wasted energy is reduced by 85%
- Reduces airstream heat gain and generated condensate
- For more details, refer to the X-Stream™ sales literature

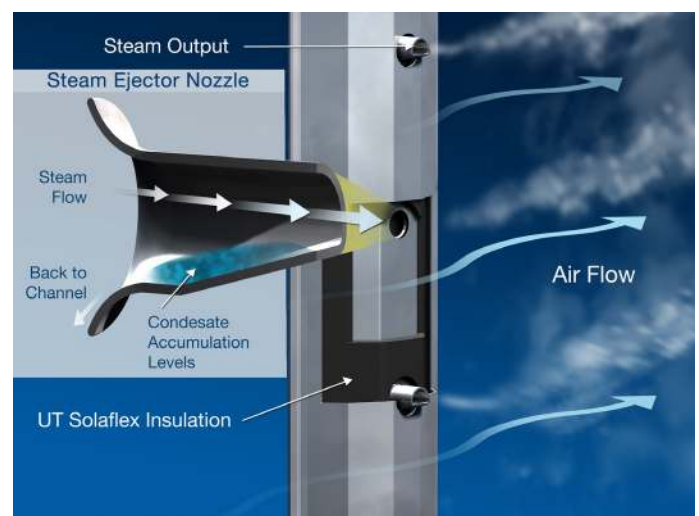

Jacketed Tube Steam Distribution

This configuration consists of a single tube or multiple horizontal tubes on a common vertical header. Upon a demand for humidity, the ESC controller opens the isolating valve to preheat the outer jacket. This prevents any condensate from forming in the inner tube that could wet the duct or AHU floor when steam is flowing through the tubes' nozzles. When the jacket reaches its operating temperature, the ESC controller slowly opens the steam modulating valve feeding steam directly to the inner tube(s). The steam escapes the tube(s) through multiple calibrated nozzles and mixes with the airflow to maintain the desired humidity level.

Single Tube

- Mainly for duct installations
- Low capacity applications: 2 - 77 kg/h
- Average non-wetting distance
- Pre-configured ESC controller manages sequence of operation

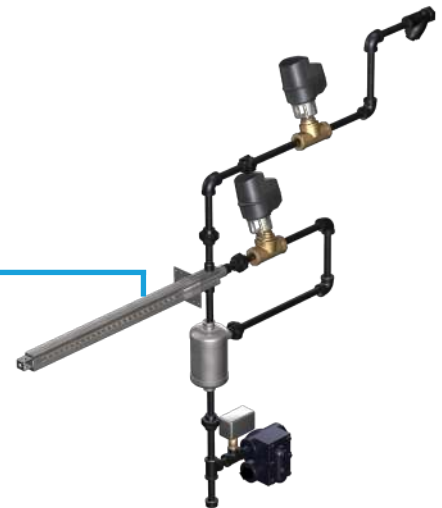

Multi-Tube

- For duct or AHU installations
- Medium to high capacity applications: 2 - 750 kg/h; higher capacities also available
- Short non-wetting distances
- Pre-configured ESC controller manages sequence of operation
- Optional pressurized condensate return (PCR) system

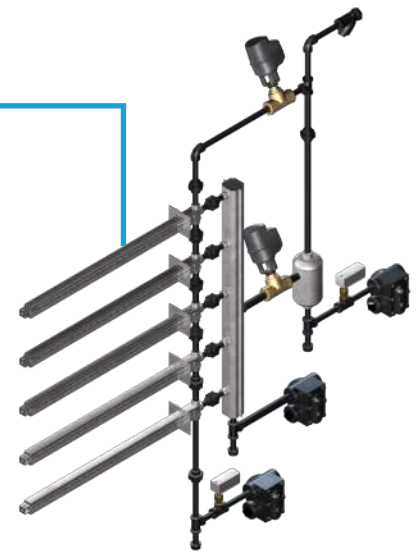

Mini Rack

Same as Multi-Tube plus:

- Designed for limited space installations such as reduced duct height
- Tubes pre-assembled on header

Breakthrough Innovation for Direct Steam Injection Humidifiers

Pressurized Condensate Return System (PCR)

- No gravity drain
- No maintenance
- Reuse condensate
- Save energy

The Neptronic pressurized condensate return (PCR) system returns condensate generated within the steam dispersion tubes of a direct steam humidifier back to the steam source. Presently, the only other available technology is a pressurized steam humidifier with a heat exchanger (or re-evaporator).

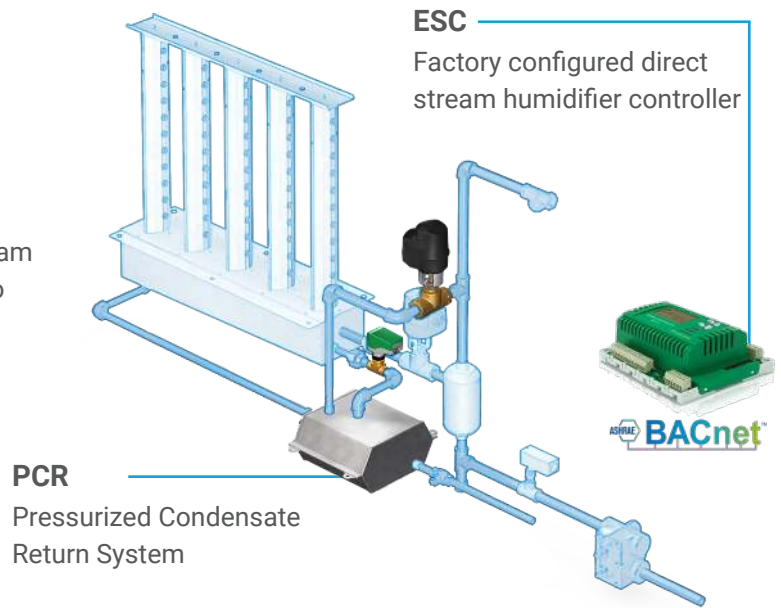

Why should you choose a humidifier with a PCR system?

Description	Neptronic PCR System (Pressurized Condensate Return)	Re-Evaporators (Internal Heat Exchanger)
Why use it?	No gravity drain required. Return humidifier condensate to steam source rather than waste to drain or complicated re-pressurization systems	
Real-time monitoring	Yes	No
BMS integration	BACnet or Modbus	No
Maintenance	Not required	Systematic verification is a must*
Cleaning	Not required	De-scaling*
Downtime	None	During maintenance or when equipment offline due to fouling*
Flooding of header	None	Possible due to reduced capacity due to fouling and standard piping configuration*
Accessibility	Outside the duct for easy access	Standard cleaning procedure requires access to the top of header often located in duct (may require duct access door)*
Compatibility	Insulated and non-insulated steam distributors and headers	Only insulated steam distributors and headers
Installation	Lowest clearance with simple and flexible installation due to small modular components	Higher clearance and integral design forces components below duct, resulting in potential ceiling clearance issues

Patent Pending

*See manufacturer's manual for more information

Humidifier Product Line



Electric



SKE4

- Capacities from 5 - 120 kg/hr
- Remove chamber easily, without tools
- Outdoor unit available

Gas Fired



SKG4

- Capacities from 50 - 400 kg/hr
- Modular design
- Outdoor unit available

Steam to Steam



SKS4

- Capacities from 15 - 670 kg/hr
- Scale management system for easy maintenance
- Insulated external panels

Residential



SKR

- Capacities from 3 - 5 kg/hr
- Permanent cleanable chamber
- Reliable siphon drain

High Pressure Atomizer



SKH

- Capacities up to 2100 kg/hr
- Up to 3 zones
- Installation in-duct or in-space

Evaporative



SKV

- Free cooling up to 12°C
- Custom design to fit your application
- Hygienic operation with silver ion dosing system

Direct Steam



SKD

- Capacities from 2 - 750 kg/hr
- Jacketed or Multi-Steam™ SD/HD
- Unique electronic steam controller
- Optional pressurized condensate return (PCR) system

Steam Distribution



Distribution

- Multi-Steam™ SD/HD distribution
- S.A.M. & S.A.M.E2 wands
- SDU (Space distribution unit)

Humidity Controls



Controls

- Humidity controls/sensors
- Safety controls
- BACnet compatible

MANUFACTURER OF ■

- HVAC CONTROLS
- ELECTRIC ACTUATORS
- ACTUATED VALVES
- HUMIDIFIERS
- ELECTRIC HEATERS



www.neptronic.com